



**RAINSCREEN PROGRAM 2010**

## RAIN SCREEN SYSTEM INSTALLATION DATA AND DETAILS

### 5/16" RICHLITE ARCHITECTURAL WALL PANELS APPLIED OVER A SHEATHED STUDWALL BY MEANS OF A FIELD ASSEMBLED RAIN SCREEN SYSTEM

#### DESIGN CONCEPT

The Rain Screen principle is a superior method for wall construction, to prevent water leakage, and provide a weather resistant exterior design. The exterior wall panel is still intended to deflect most of the water that contacts the wall. However, a one inch cavity is provided behind the wall panels. If water does penetrate the facade, it reaches the cavity and cannot move further into the wall assembly. Instead, water in the cavity will drain down the inside face of the wall panel or on the waterproof wall membrane at the other side of the cavity, and it will be deflected and drained out of the wall assembly. In practice the cavity acts as a capillary break to remove the capability of water to stagnate inside the walls. Therefore, this eliminates the need to caulk the panel joints, as the outer wall panels are not completely sealed.

Combining the beauty of Richlite panels with the forward thinking of Rain Screen technology, allows the architect to design without the need for exterior caulking. Utilizing Rain Screen technology, Richlite architectural panels are attached to an aluminum frame system over the watertight wrapping of the building. This creates a back-ventilated, pressure equalized system that of itself aids in moving moisture away

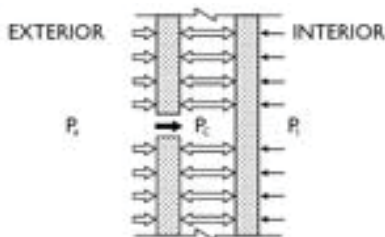

from the building. With the weather barrier behind the system away from the damaging effects of weather, your project will be watertight year after year without the risk of a caulk joint failure. In general, only minor modifications to conventional studwall construction are required. Care should be given in the selection of materials to contribute to a flat, aesthetically pleasing finished installation. Exterior sheathing, protected by the weather barrier, provides a leveling plane for the

panel assembly and functions as a secondary barrier to air and water infiltration. Extruded Aluminum Hat Channels are positioned continuously at each panel perimeter and to intermediate Extruded Aluminum J-Channels, not more than 24" O.C. These extrusions have a 1/8" wall thickness. The Extruded Aluminum Hat and J-Channels are firmly fastened through the weather barrier and sheathing into the horizontal steel backing plate (18 gauge min.)\*, using Stainless Steel fasteners. For convenience, slots are provided in the extrusions approx. every 24 inches for attaching to the building. \*For installations with outboard insulation with continuous Z-channels, the steel backing plate is not necessary.

#### SYSTEM LIMITATIONS

This system is applicable to 5/16" Richlite panels, maximum size 60"X120", used on buildings designed for maximum wind loads of 40 pounds per square foot. (For wind loads over 40 pounds, contact Richlite) The system is stick built, field assembled, and set from exterior staging.

Success in setting Richlite panels in a Rain Screen system is dependent upon care in the selection of materials for both performance and compatibility, a thoroughly planned installation procedure, plus, of course, careful workmanship and quality control. Richlite's technical staff should be consulted in early design or construction stages to review all construction applications.

#### DESIGN NOTES

##### 1. Subwall Construction

Given design loading conditions, deflection of the wood or light-gauge steel studwall must be limited to L/240. Control and relief joints, as applicable to the structure, must be incorporated to prevent transfer of undue stresses (caused by structural movement, deflection, and hygrometric and thermal expansion and contraction) to the exterior wall panels. The wall must be laid out with a horizontal steel backing plate (18 gauge min.)\* to accommodate structural fasteners for each Extruded Aluminum Hat

or J-Channel, in addition to attachment of exterior sheathing and any required interior-wall surfaces. The sub wall construction should be erected plumb and true with the maximum variation from the true plane not to exceed 1/8" in 10'. As a barrier to air and water infiltration into the finished wall assembly, the sheathing should be protected by a layer of watertight weather barrier.

***This data is presented as a technical guide to architects, engineers and contractors in preparing specifications and installation. Final requirements should be verified by a qualified engineer or architect.***



## 2. Panel Layout

Cut-to-size panels are taken from standard stock sheets so the net installed cost is directly affected by the gross square footage of stock sheets required for the project. To minimize waste, it is important to plan finished modules which take full advantage of the available standard sizes, 48"X96" and 60"X120". A more complete description on size and color can be found in the current Richlite brochure, and the general white paper with typical product performance and test data.

## 3. Aluminum Extruded Channels & Vent Screen

Clean, crisp joinery maintains an architectural integrity unmatched by other systems. Aluminum Hat Channels and J-Channel extrusions (as appropriate for each joinery condition on the project) are made of mill finish aluminum, having a 1/8" wall thickness. The extrusions



can have an anodized finish or be Kynar painted. Bearing surfaces are dimensioned to allow generous clearances, including cutting and erection tolerances, plus provide proper contact area. The Vent Screen is made of Aluminum, and has generous slots for air flow and water drainage. (See Base drawing, page 11, for installation details). The Vent Screen can also be used over windows or doors. (See drawing on page 16 for installation details).

The drawings on Pages 4, show details of the Extruded Aluminum Hat Channel and Extruded Aluminum J-Channel. Available in 10' lengths. The Hat Channel is used for the Vertical Joint between two adjoining Petrarch architectural panels. The J-Channel is used as the center support or vertical Mid-panel. A clearance of 3/8" min. must be maintained between all vertical and horizontal wall panel placement.

Extruded channels are required continuously at each panel perimeter and to intermediate midpanel vertical joint **not more than 24" O.C.**



In this system, the main vertical joint and vertical mid-panel joint run continuously. Allow a min. of 1/4" clearance for coping, and a min. of 3/8" clearance from the base sill. The erection sequence begins with placement of the Vent Screen, the Vertical Hat and J-Channel extruded parts; followed by installation of the Richlite architectural wall panels. Extruded channels are fastened with Stainless Steel screws, through the sheathing into the metal studs or other solid framing members. (Subject to approval by Project Engineer.) Richlite panels are secured to the framing with Stainless Steel screws in a variety of methods, either exposed or hidden. Stainless steel screws should have a corrosion resistant inorganic coating, like Dacroment, Magni or equivalent. Wall panel fasteners are located within 1" of both ends of each length and no more than 24" O.C. in between. Actual spacing depends on design & wind loads, panel size and shape.

Typically, thermal expansion and contraction can be anticipated to be equal at both ends of a length of extruded channel. The extrusions are attached through generously slotted holes. Channel lengths must be dimensioned, cut, and erected to allow free-floating thermal movement over the temperature gradient to

which the installation will be exposed. The aluminum extrusions have a similar thermal coefficient of expansion to that of the Richlite wall panels. However, in planning, extrusion lengths should be dimensioned as if they were independent and unrestrained, using aluminum's 13.0 X 10<sup>-6</sup> in/in °F coefficient of expansion. A 3/8" gap should be allowed between abutting parts both vertical and horizontal. The Aluminum Extrusions for framing are supplied by Richlite Company. For more information, contact:

**Richlite Company**  
**624 E. 15th Street**  
**Tacoma, WA 98421**  
**Phone: (888) 383 5533**  
**Fax: (253) 383 5536**  
**info@richlite.com**



#### **4. Inspection, Maintenance and Cleaning**

A Rain Screen system should be inspected on a routine basis after installation to assure that damage, which could affect its structural integrity, has not occurred. The inspection program should be in accordance with the responsible structural engineer's recommendations. A minimum schedule would be to inspect twice in the first year and once a year thereafter, supplemented by inspections which reasonable judgment would deem prudent following such occurrences as a severe storm, vandalism, civil disorder, or the like. Appropriate protective measures and corrective steps should be promptly implemented anytime structural damage is discovered.

To keep the installation looking clean, the owner should include panel washing in his annual maintenance schedule, perhaps in conjunction with window washing. The actual schedule will vary depending on factors such as the occupation and use of the building, location relative to atmospheric and environmental conditions, and the relationship of the wall panels to surrounding materials. Scrubbing with a solution of mild detergent or soap and water, followed by a clean water rinse, using standard commercial cleaning techniques, is all that is normally required.

## **INSTALLATION NOTES**

### **1. Panel Characteristics**

All installation crew members should be familiarized with the characteristics of Richlite architectural panels. To a large degree, the responsibility for an aesthetically pleasing, trouble-free installation rests with the installer. The final product is often judged on the basis of the installer's skill and workmanship, and touch up. For instruction on receiving, storage, material handling, and field fabrication, refer to the general Richlite product white paper.

### **2. Subwall Inspection**

Prior to the installation of the panels, the subwall must be inspected to assure that it is in good condition. The subwall must be plumb and true, with maximum variation from true plane no more than 1/8" in 10'. Defects must be corrected before proceeding to achieve a flat solid installation.

### **3. Panel Lay Out**

Measure the wall to determine exact panel locations and mark the positions of all Vertical Hat and J-Channel Extrusions according to the shop drawings. Vertical channels run continuously and must be solidly attached over the watertight weather barrier to the sheathing and Horizontal Steel Backing Plate. Vertical channels must be positioned exactly because they directly influence the final locations of the panels on the wall. Erection tolerances for other parts can be +/- 1/8".

If intermediate stiffeners are included in the design, install stiffener plates. These may be located with more generous tolerances.

In all cases, allow for loose abutment and planned-for expansion clearances. Use one screw in each length as a stake and set all other fasteners through generously oversized or slotted holes. Fasten at each end leaving no more than 16" O.C. in between.

### **4. Panel Preparation**

Confirm that the panel is in good condition and cut to the proper size. Secure wall panels in place using appropriate fasteners as noted earlier.

### **5. Quality Control**

Finally, it is strongly recommended that the project specifications call for a job site meeting of representatives of Richlite, the architect, general contractor and the installing sub-contractor prior to the start of panel installation.

**NOTE:** The installation of Richlite panels using the Rain Screen system must conform to this design and installation data paper, dated March, 2010, or all warranties are void.

This Richlite design and installation data paper supersedes all installation instructions. Check for later additions.

# Fastening cladding panels to aluminum sub-frames



## Technical information TW-S cladding fasteners

**Material:**

TW-S: Stainless steel (grade 304, DIN 1.4567)

**Application:**

Fastening flat cladding panels to predrilled aluminum sub-frames  $\geq 0.118$

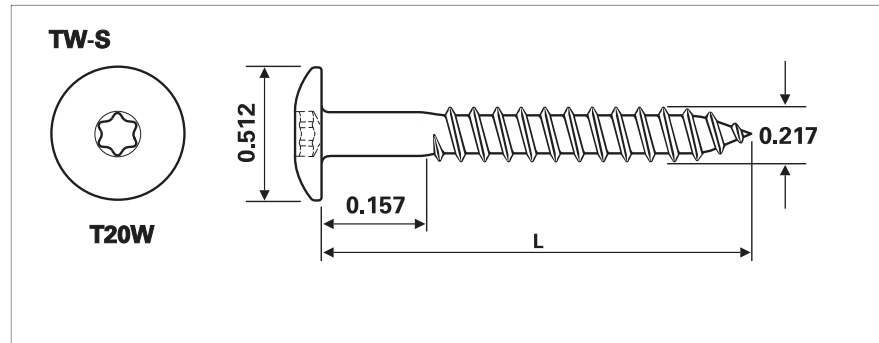

**Example / Order code**

Type	Material:	Head style ("")	Thread-diameter d ("")	Length L ("")
<b>TW-S-</b>		<b>0.512-</b>	<b>0.217x</b>	<b>...</b>
			<b>TW-S-0.512-0.217x</b>	<b>0.984 1.496</b>

**Colored fasteners**

DI 600      Z661

ZA 1/4"-universal 1/4" long      T20W

**Diameter of pilot hole in cladding panels:**  
0.335

Thickness of sub-frame:  
min. 0.118 aluminum

pilot hole  $\varnothing$  0.203

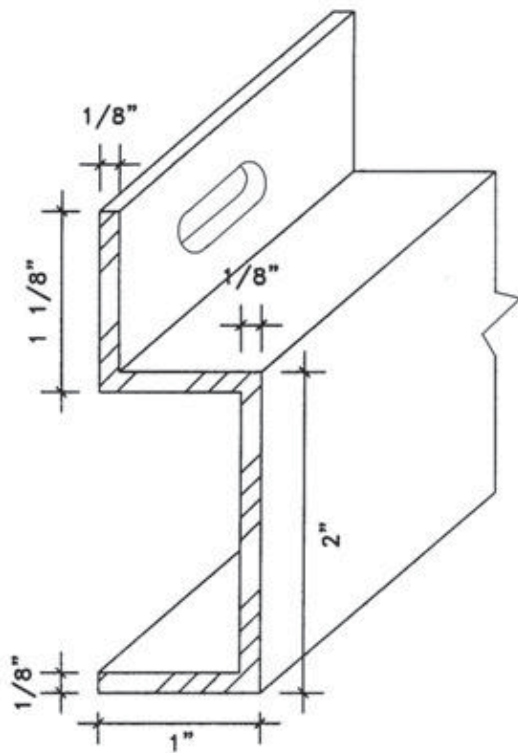

J-CHANNEL  
#12250-S

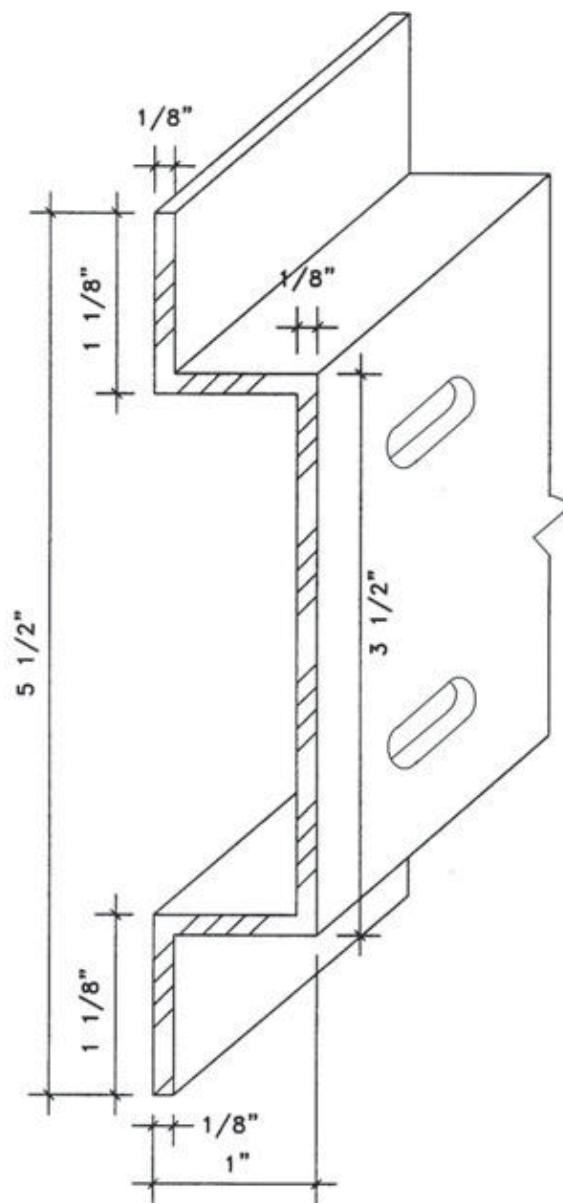

HAT CHANNEL  
#12249-S

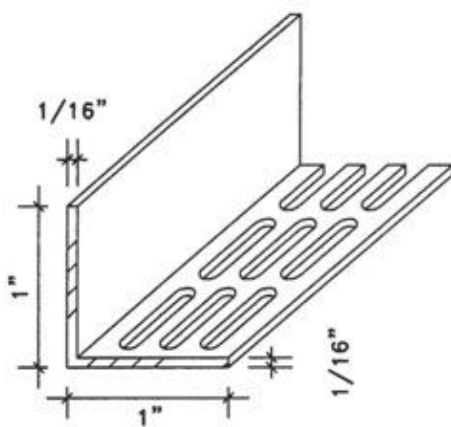

VENT SCREEN  
#12248-S

RAIN SCREEN ALUMINUM EXTRUSIONS, 6063-T5, BLACK ANODIZED FINISH  
10' LENGTHS

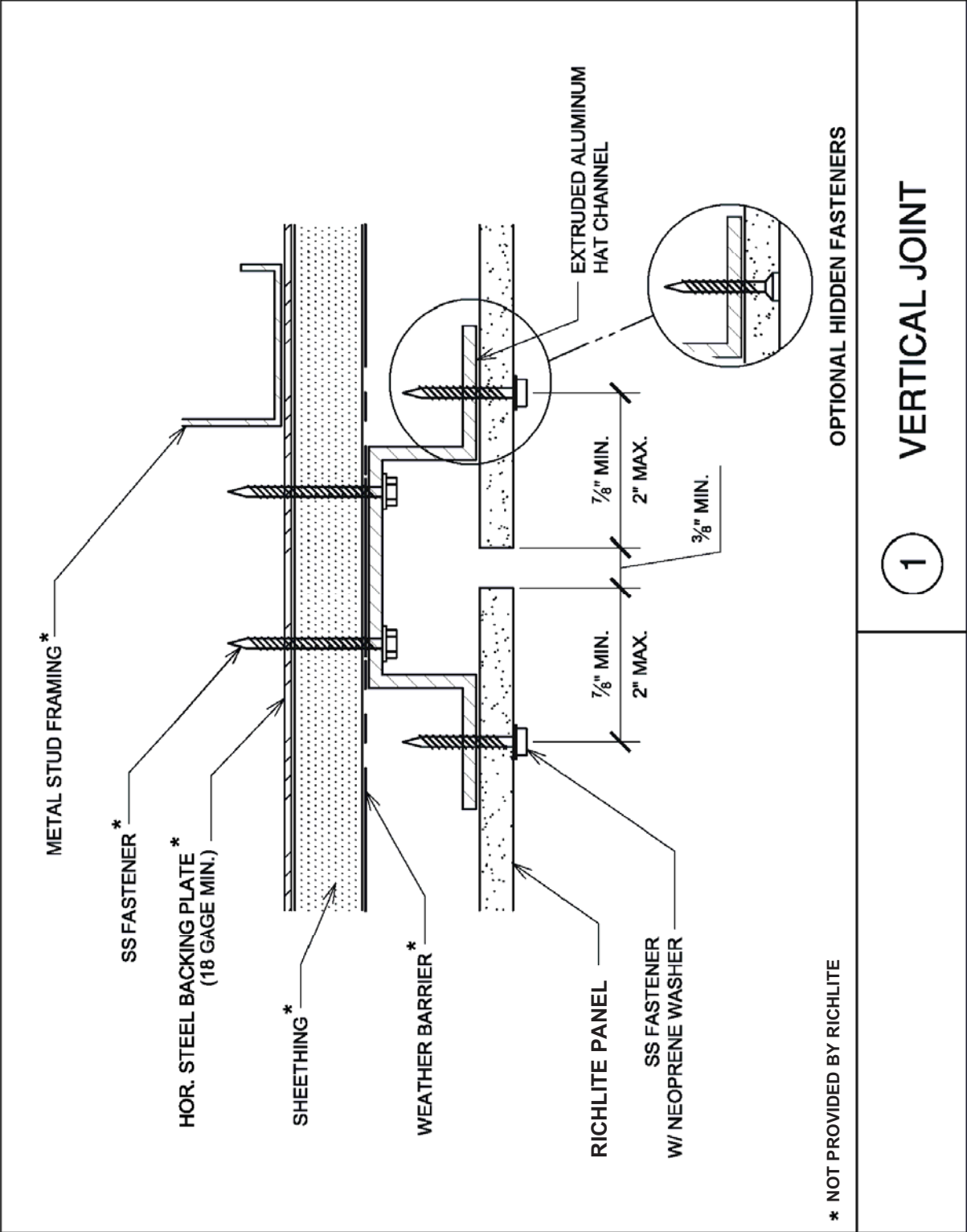

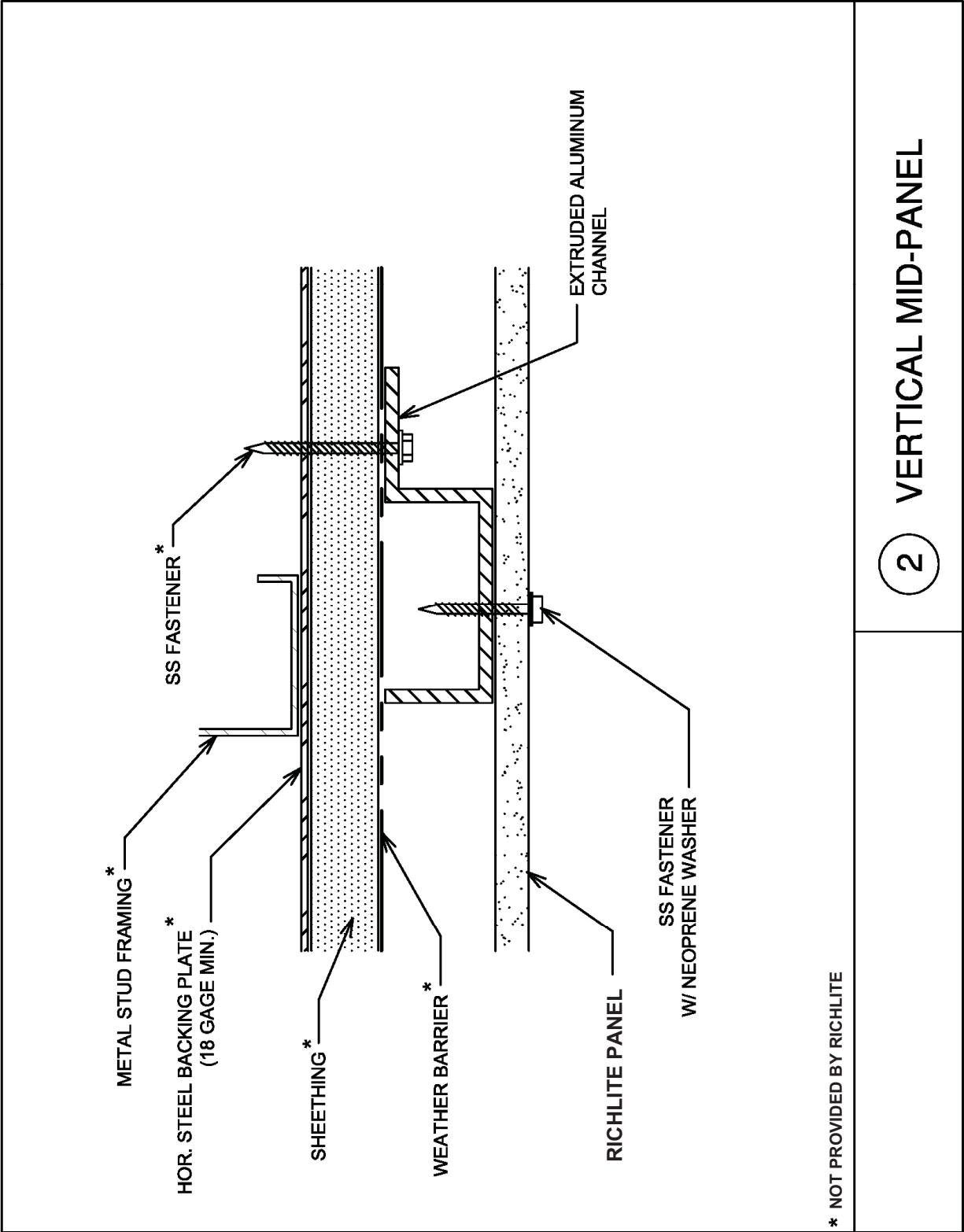

2 VERTICAL MID-PANEL

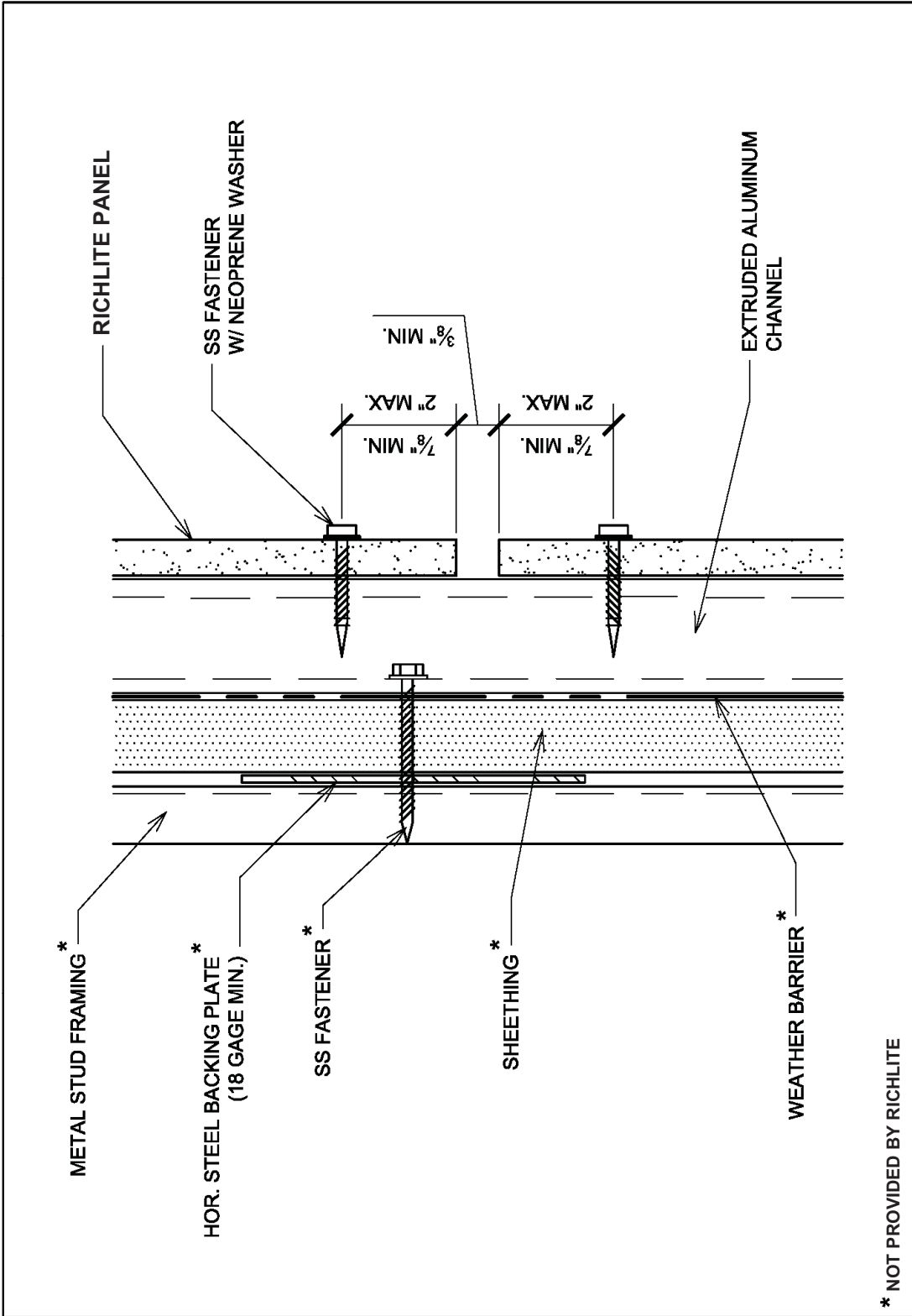

3

HORIZONTAL JOINT

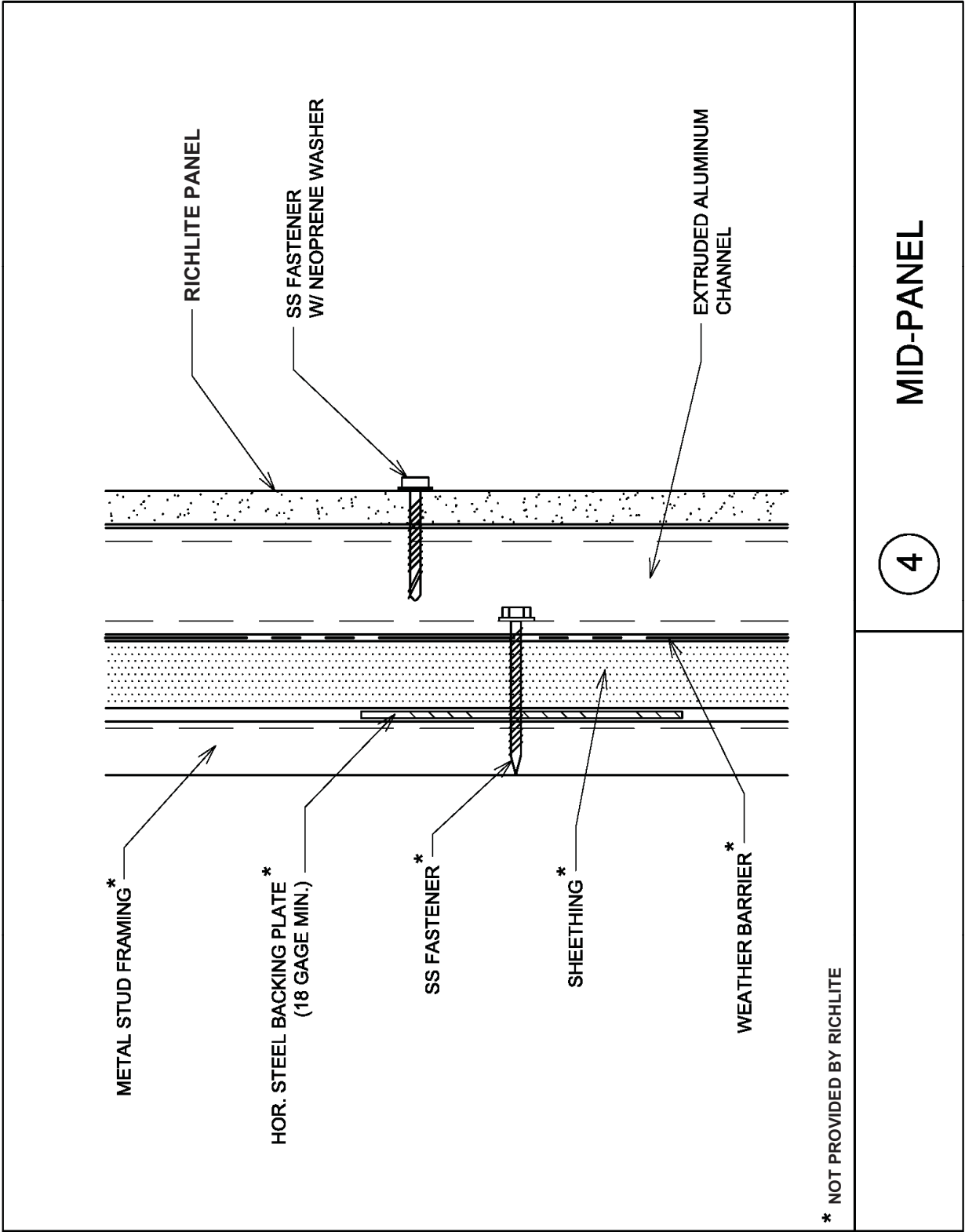

4

MID-PANEL

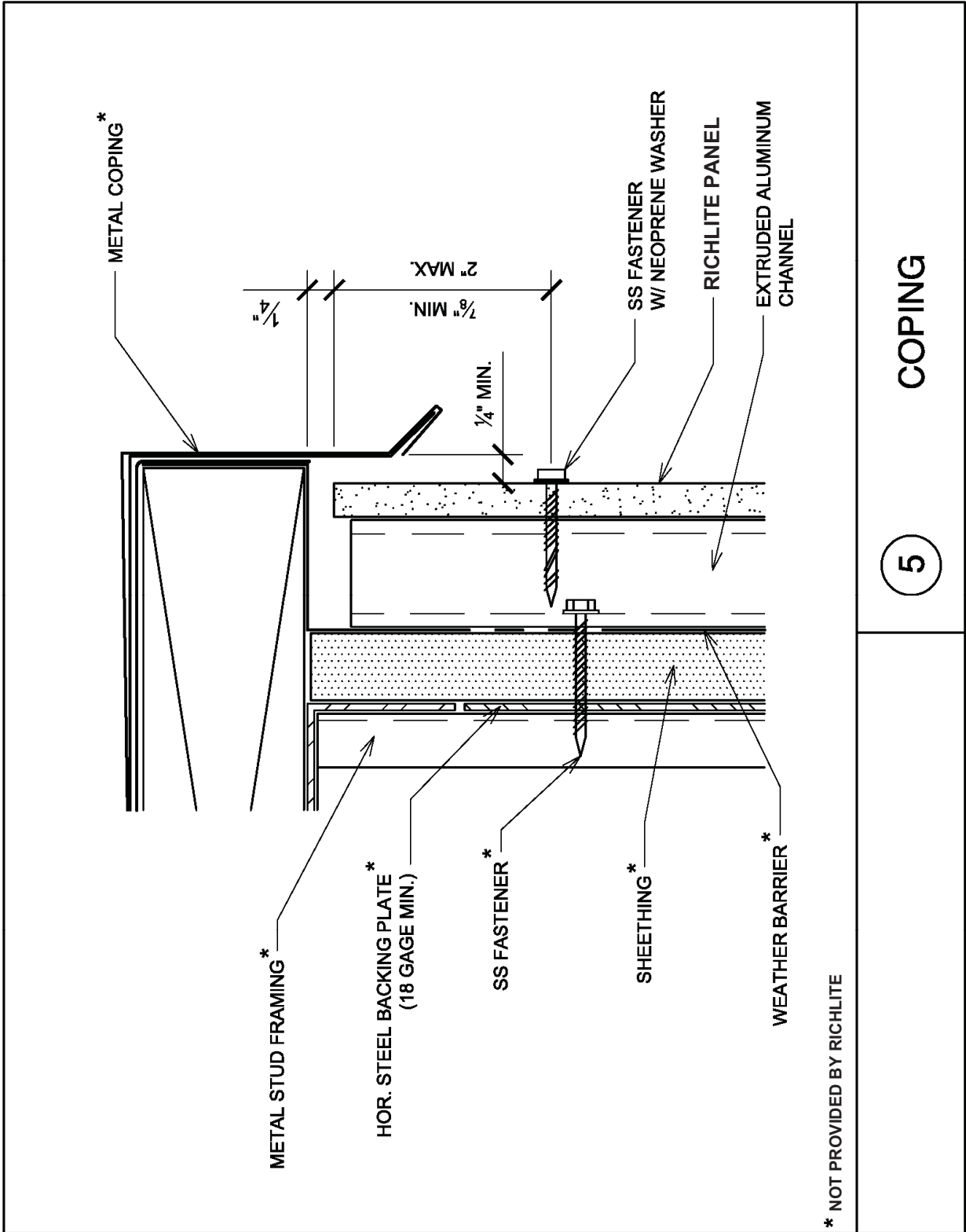

5

COPING

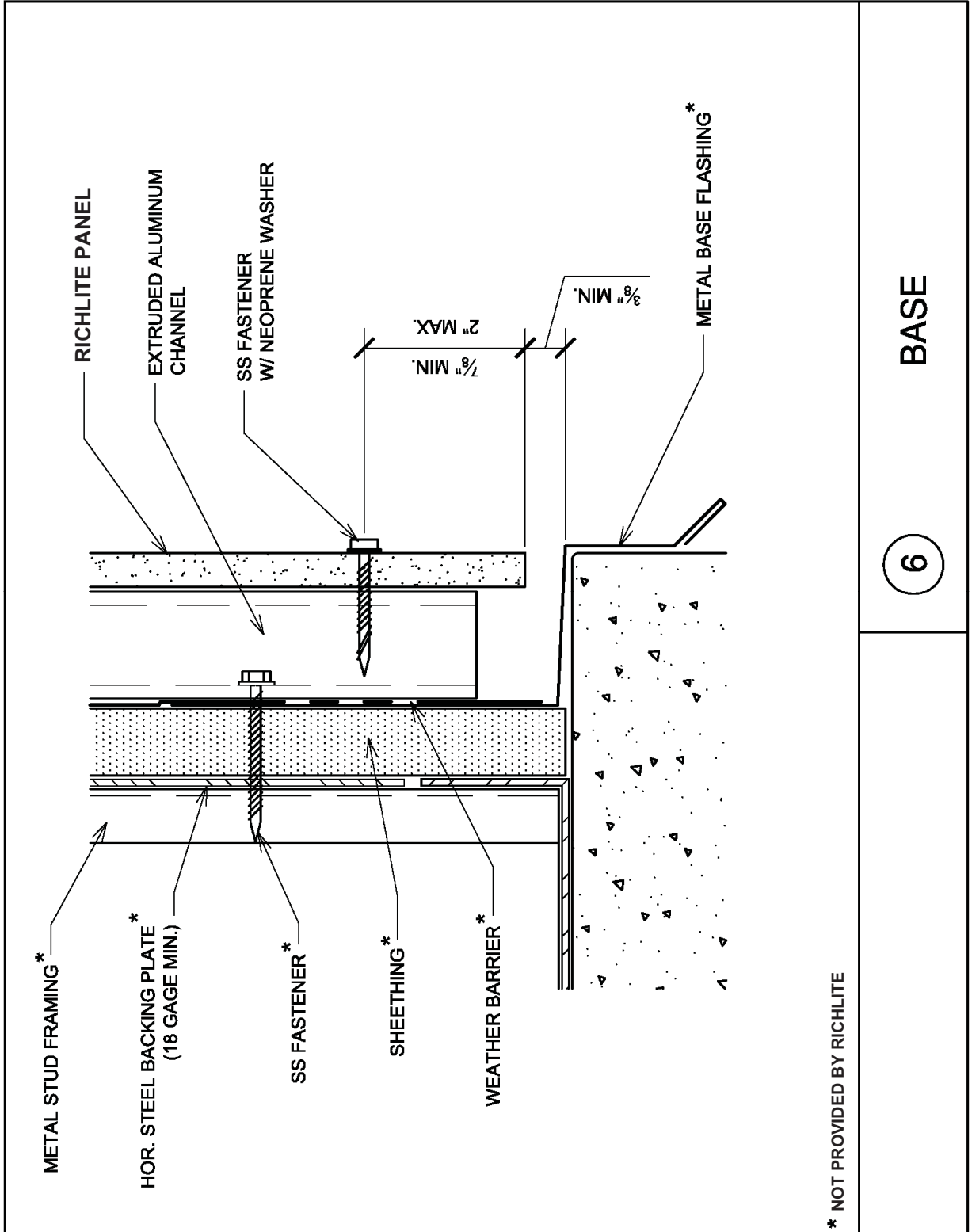

6

BASE

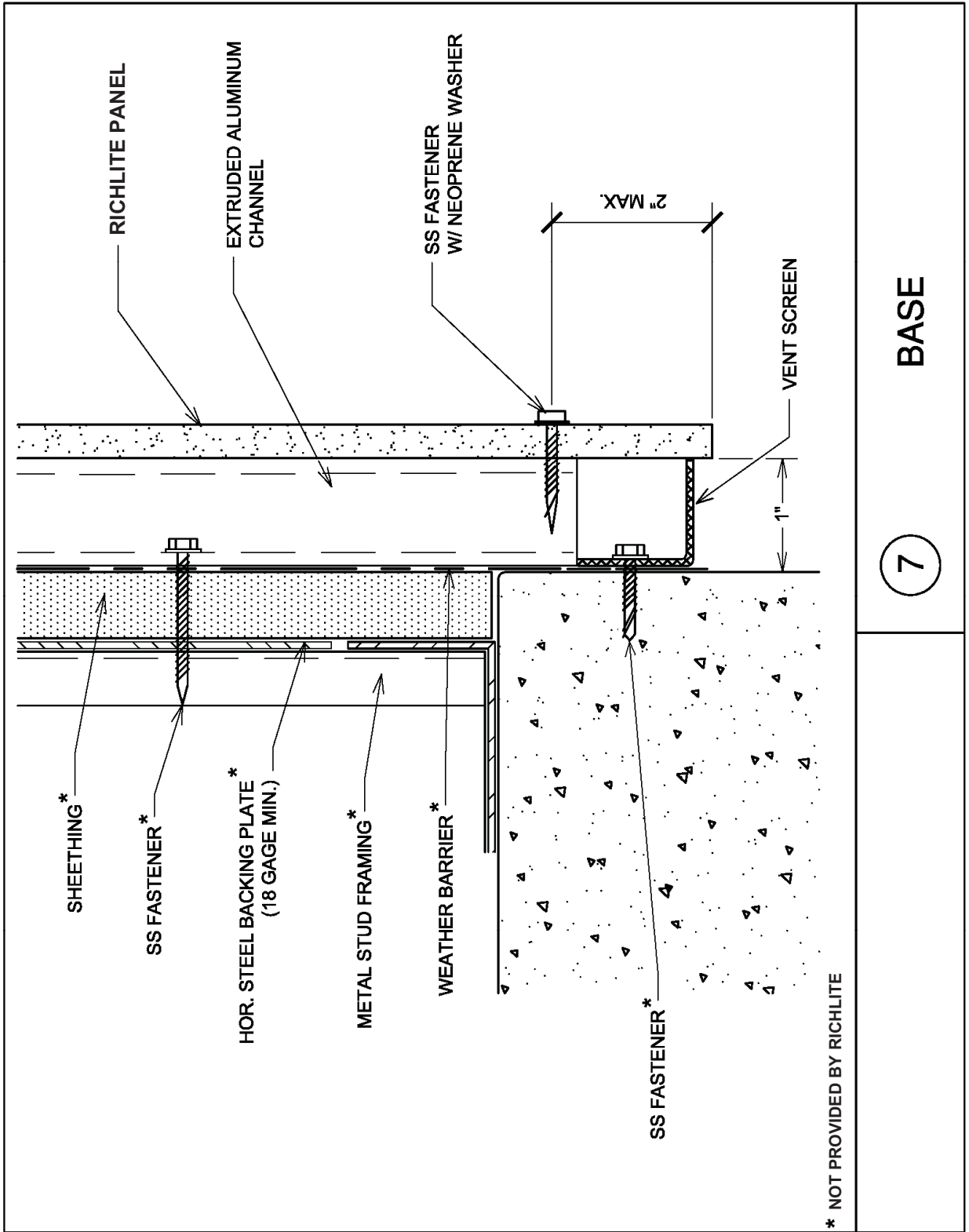

7

BASE

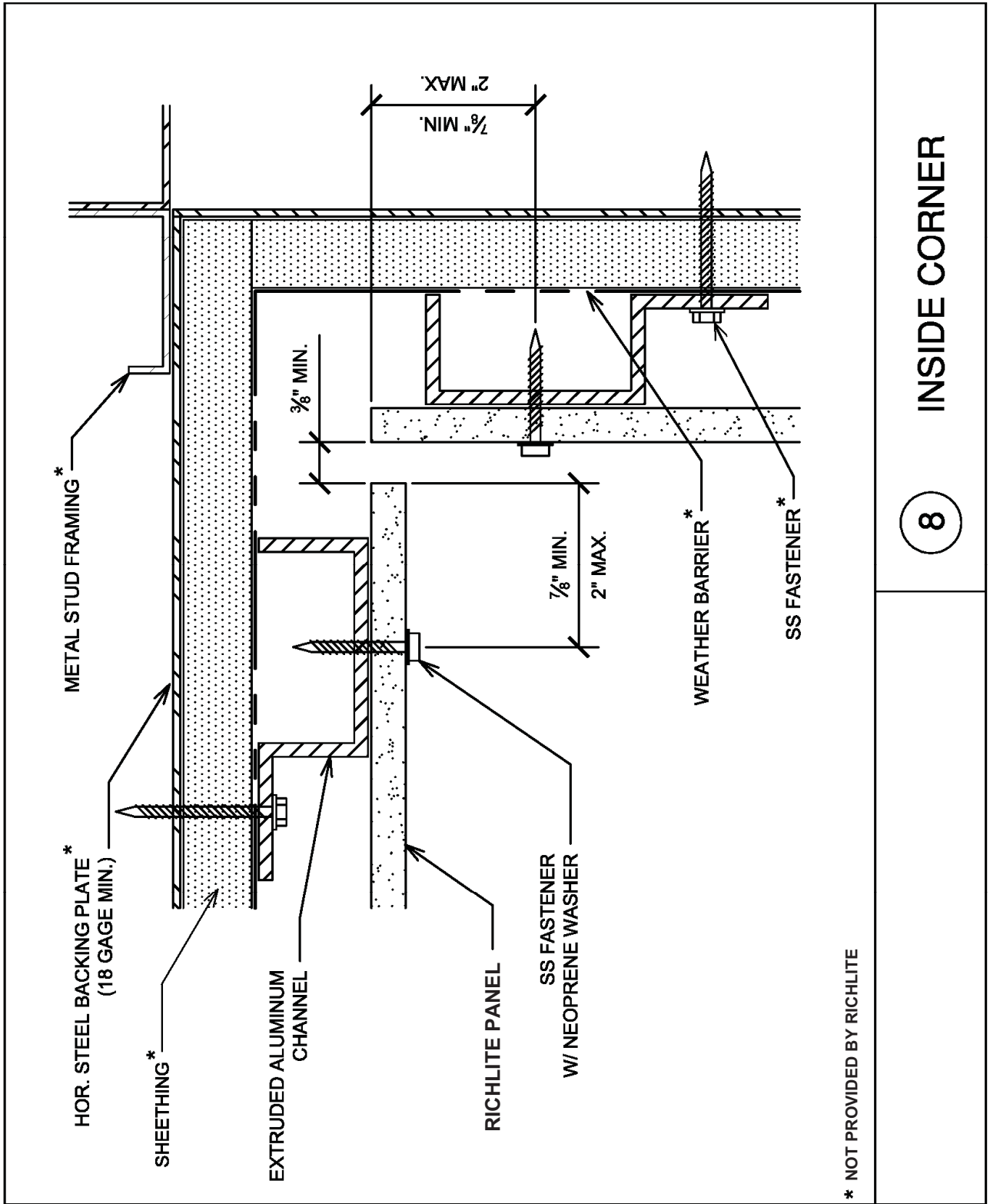

\* NOT PROVIDED BY RICHLITE

8

INSIDE CORNER

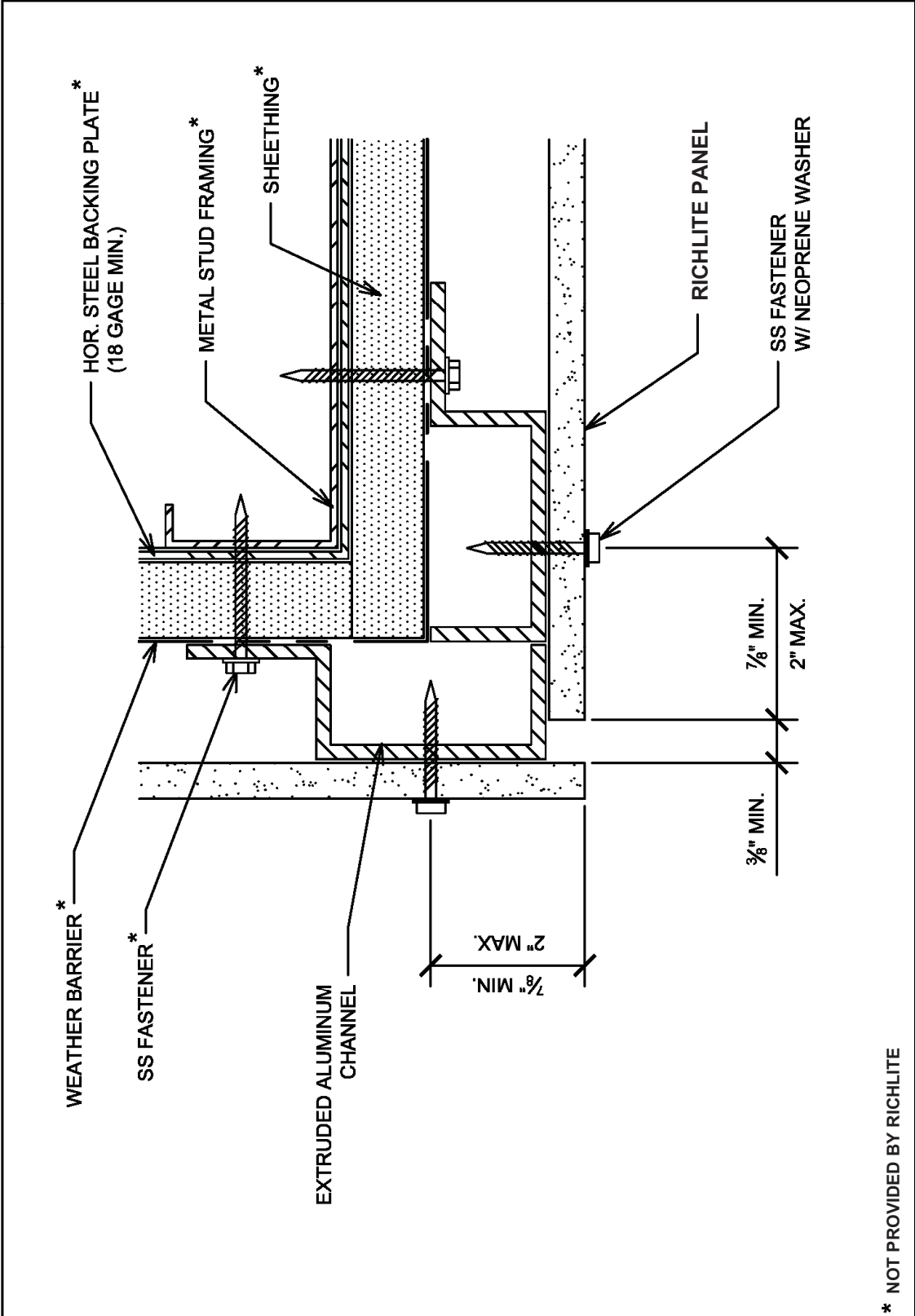

\* NOT PROVIDED BY RICHLITE

9

OUTSIDE CORNER

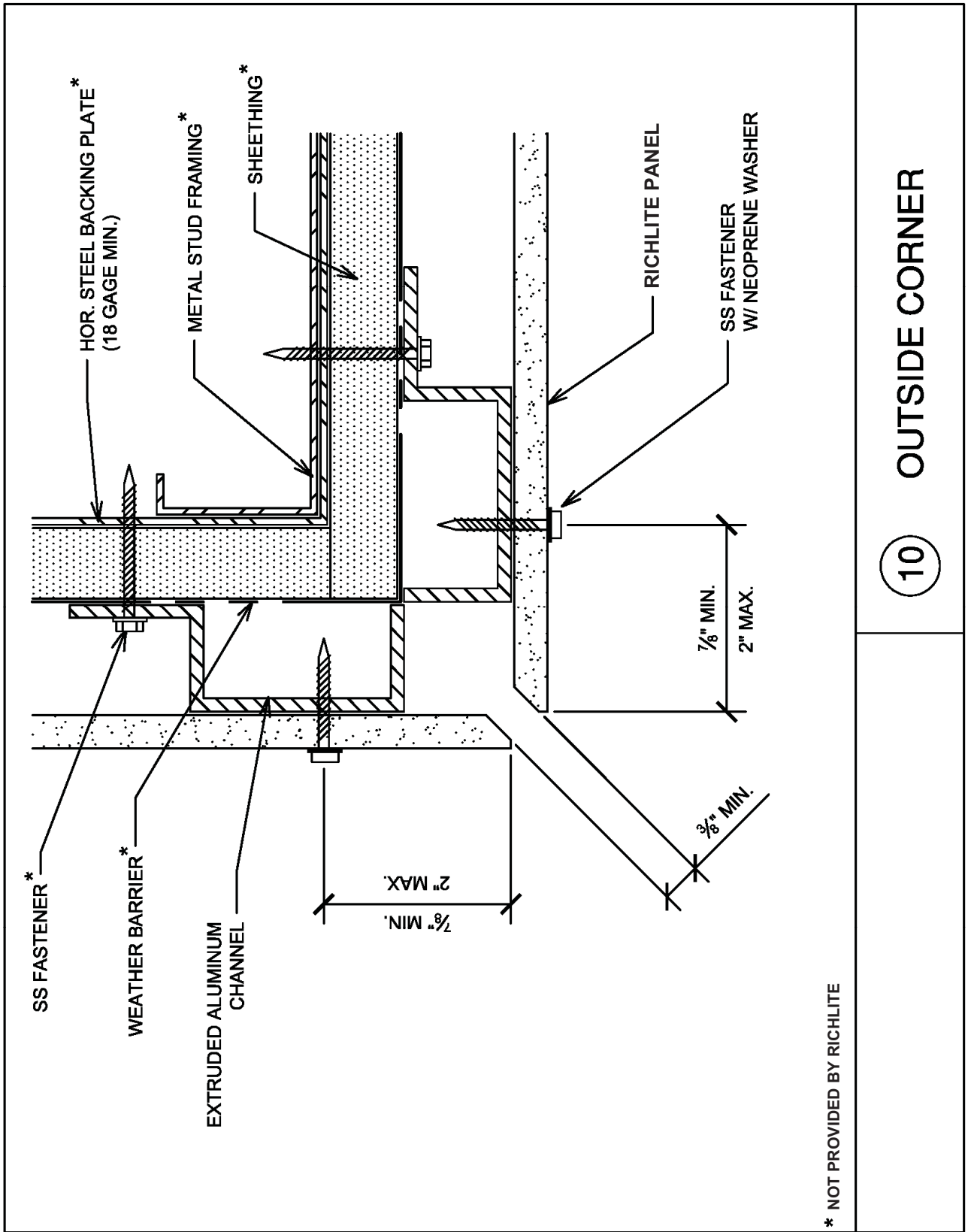

\* NOT PROVIDED BY RICHLITE

10 OUTSIDE CORNER

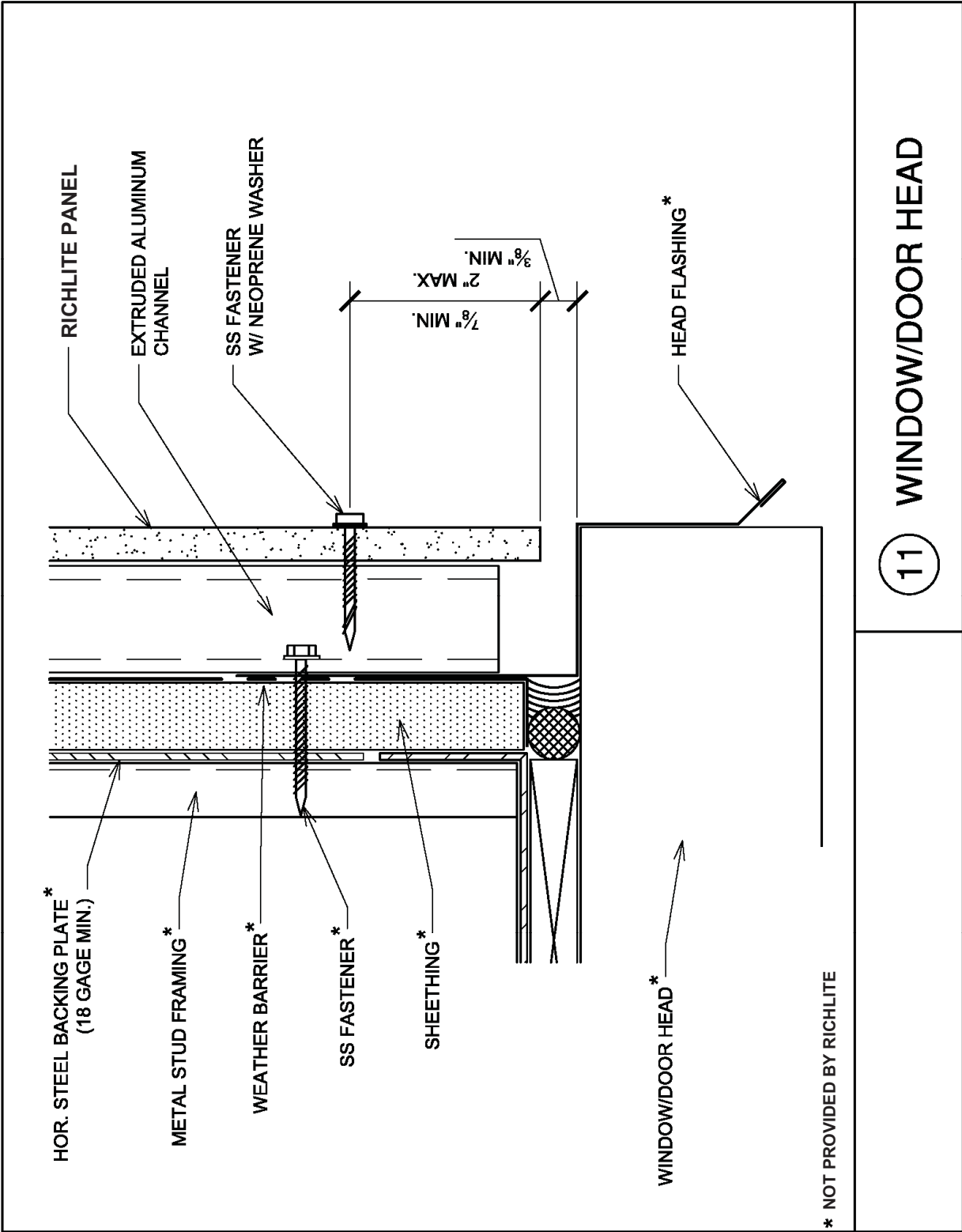

11 WINDOW/DOOR HEAD

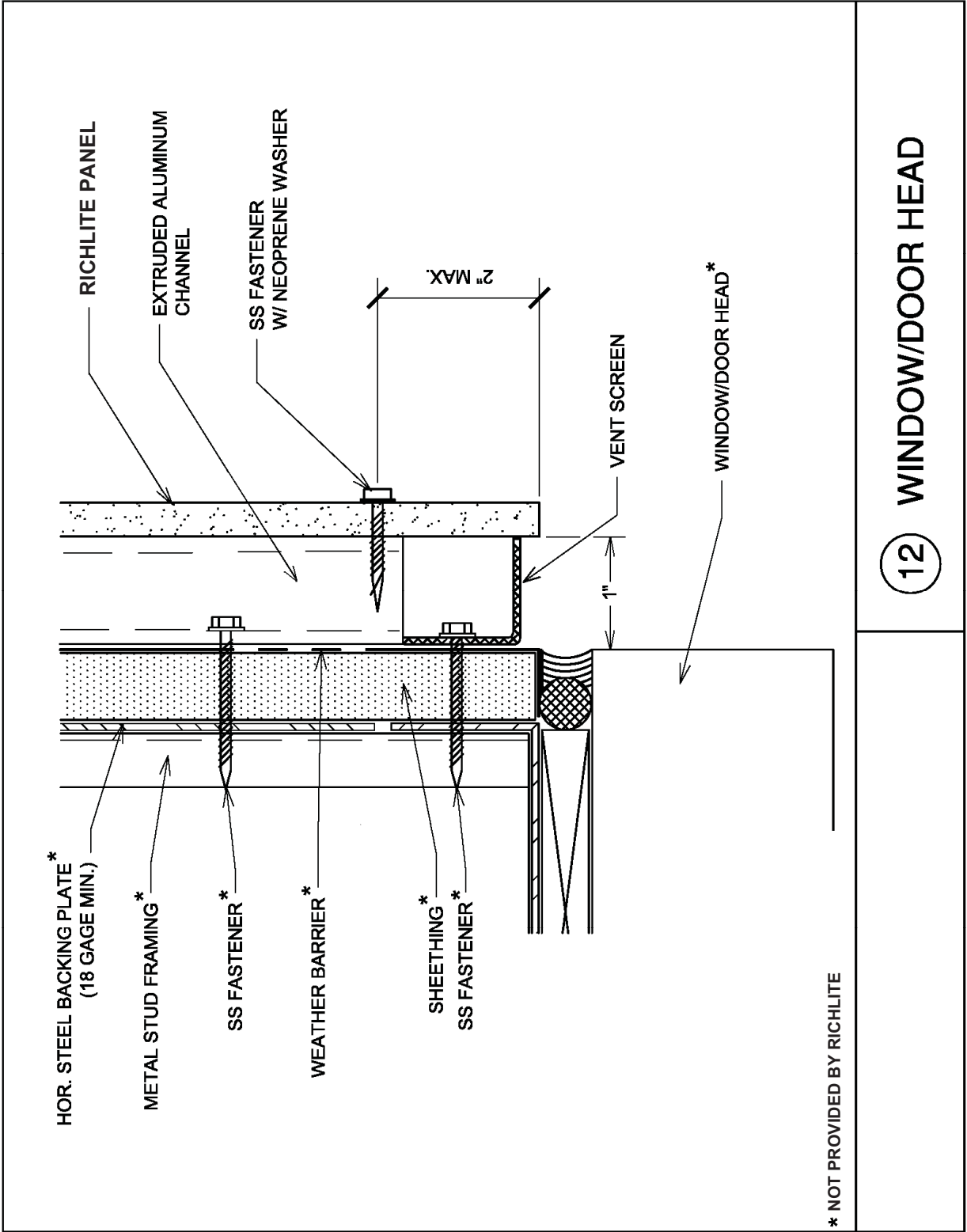

\* NOT PROVIDED BY RICHLITE

12 WINDOW/DOOR HEAD

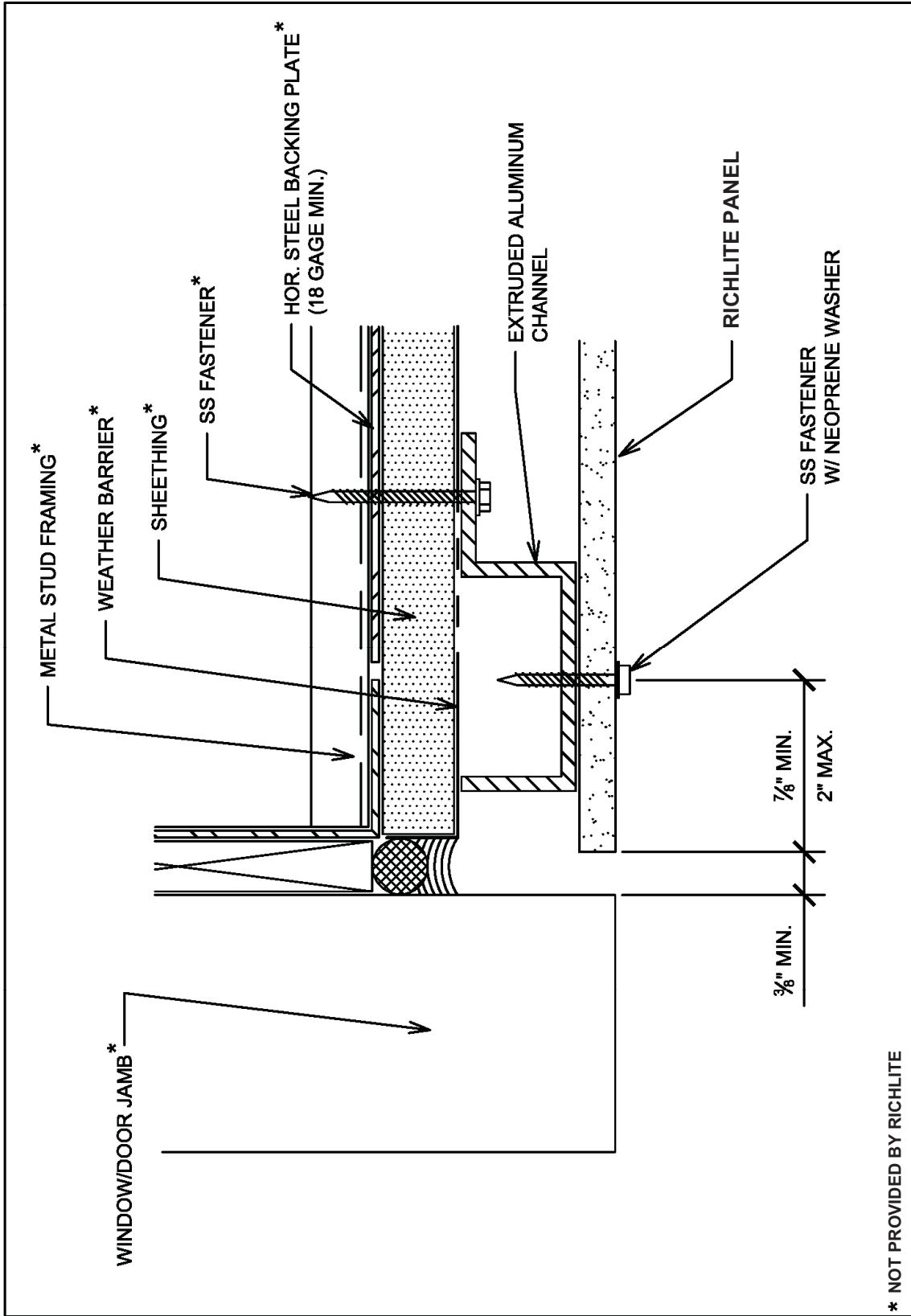

\* NOT PROVIDED BY RICHLITE

13

WINDOW/DOOR JAMB

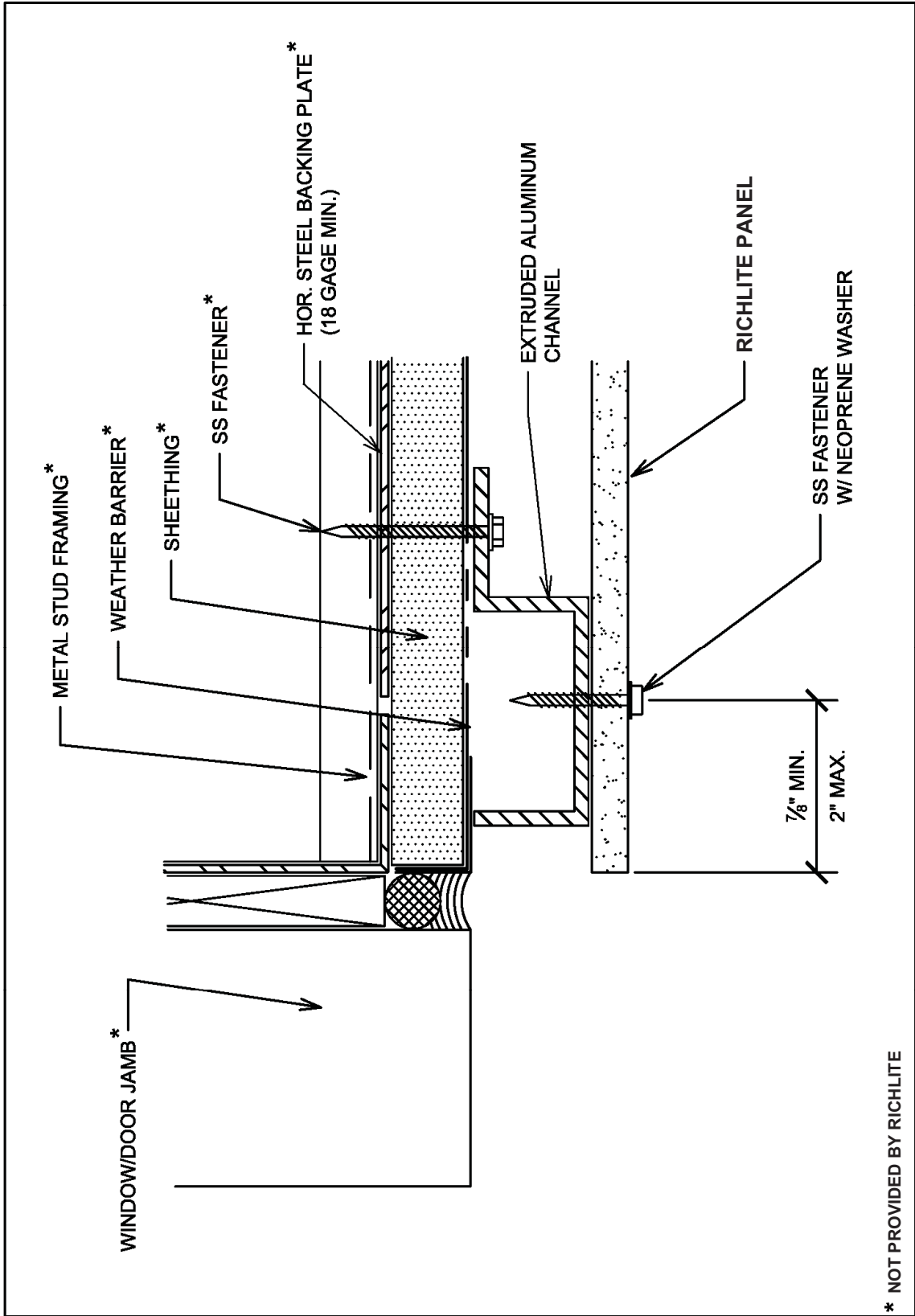

\* NOT PROVIDED BY RICHLITE

**14 WINDOW/DOOR JAMB**

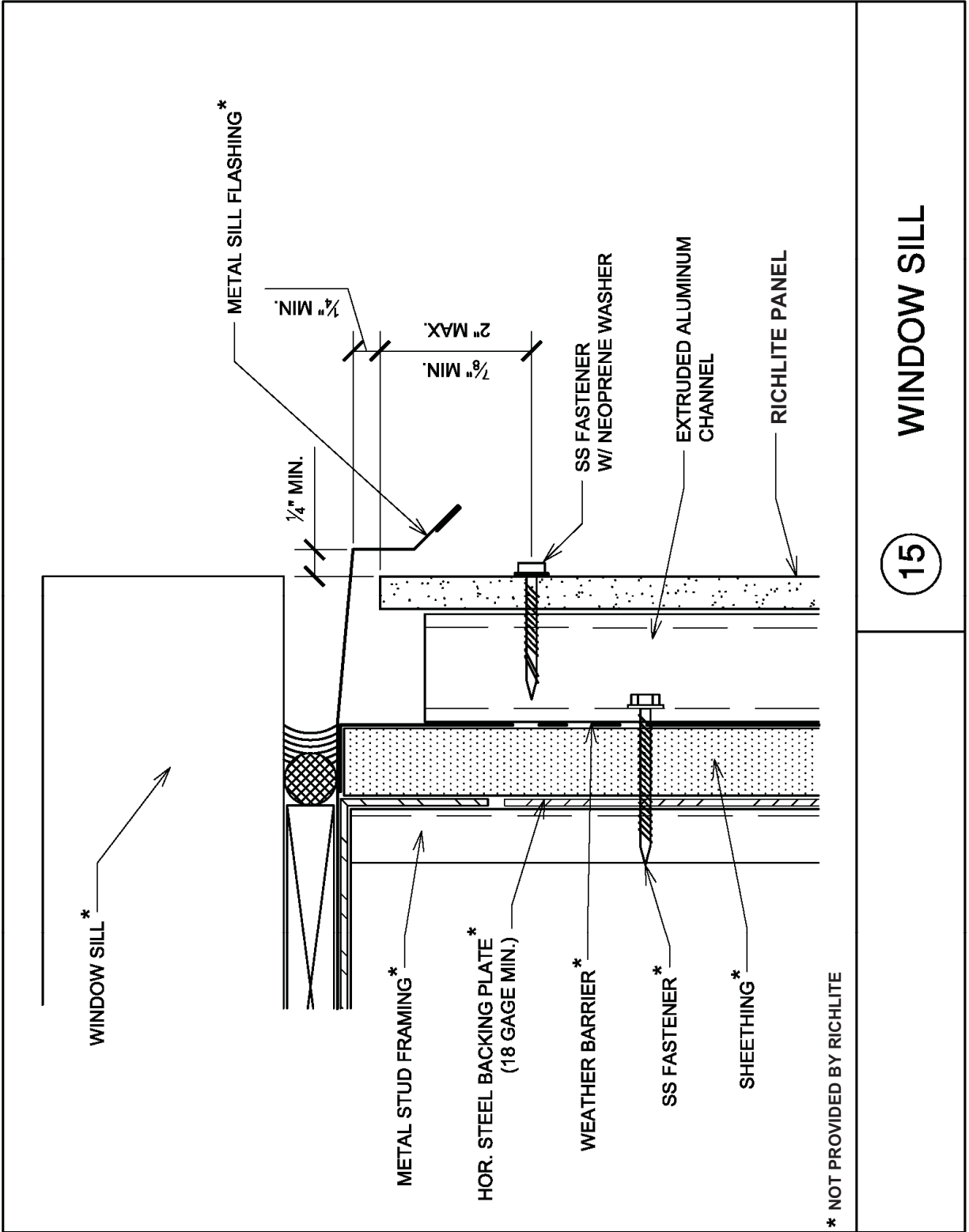

15

WINDOW SILL

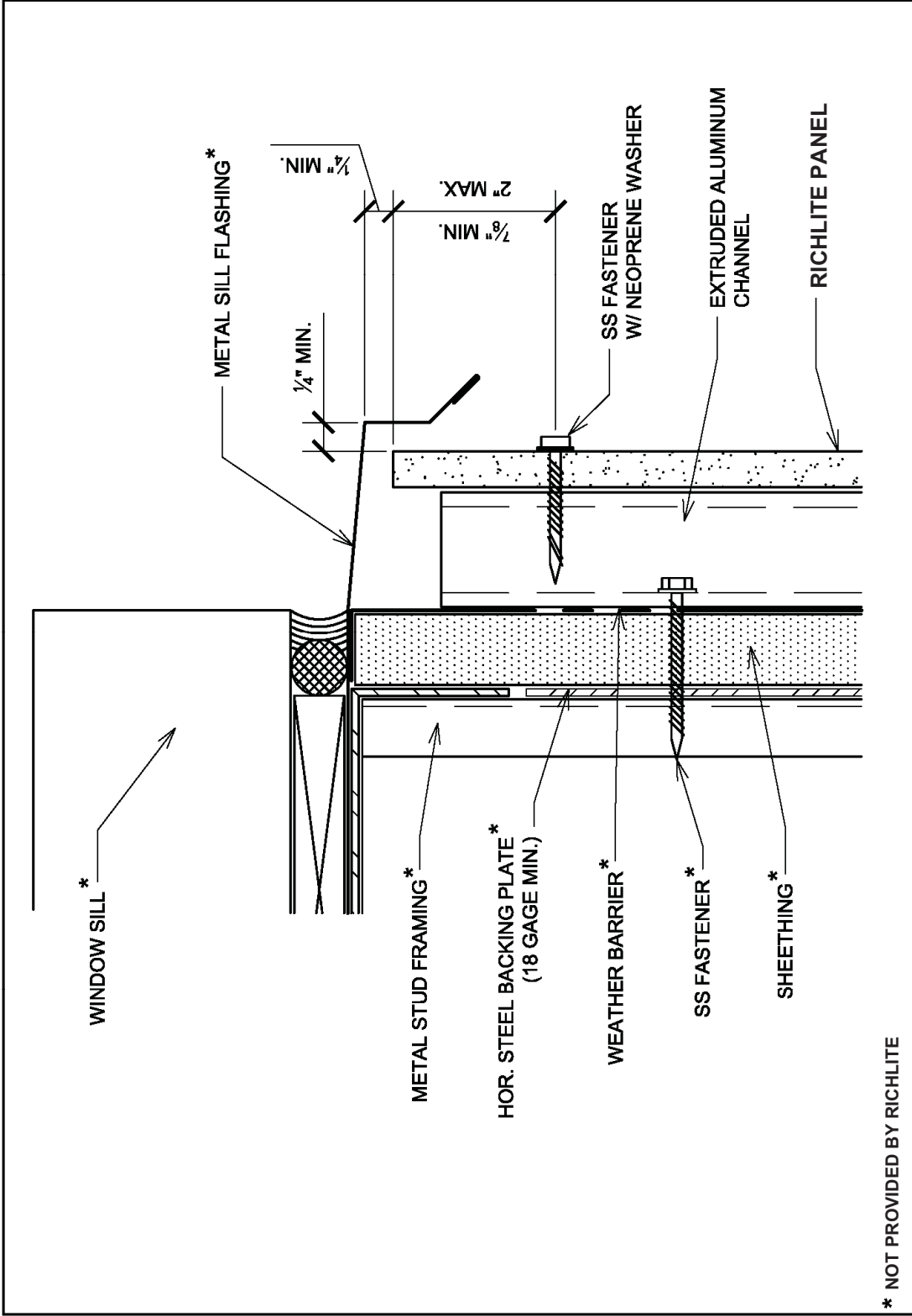

16

WINDOW SILL